



# HRL-0025-1-9 HEATLESS DESICCANT AIR DRYER GENERAL ARRANGEMENT

TOLERANCES UNLESS  
OTHERWISE SPECIFIED:

- FRACTIONS = ± 1/4 "
- ANGLES = ± 3°
- INCHES = ± 1/2 "
- FINISH = 250

THE SPECIFICATIONS AND DRAWINGS DISCLOSED HEREIN ARE THE SOLE PROPERTY OF ALTEC AIR, AND SHALL NOT BE COPIED OR USED AS THE BASIS FOR SALE OR MANUFACTURE WITHOUT EXPRESS WRITTEN PERMISSION.

### REVISION LOG

REV.	ECO.	DESCRIPTION	DATE	APPROVED
A				

DRAWING NO. **AT20-1426** REV. **A**

DRAWN: WS DATE: 9/20/2021  
 CHECKED: DATE: SCALE: N/A SHEET: 1 OF 2

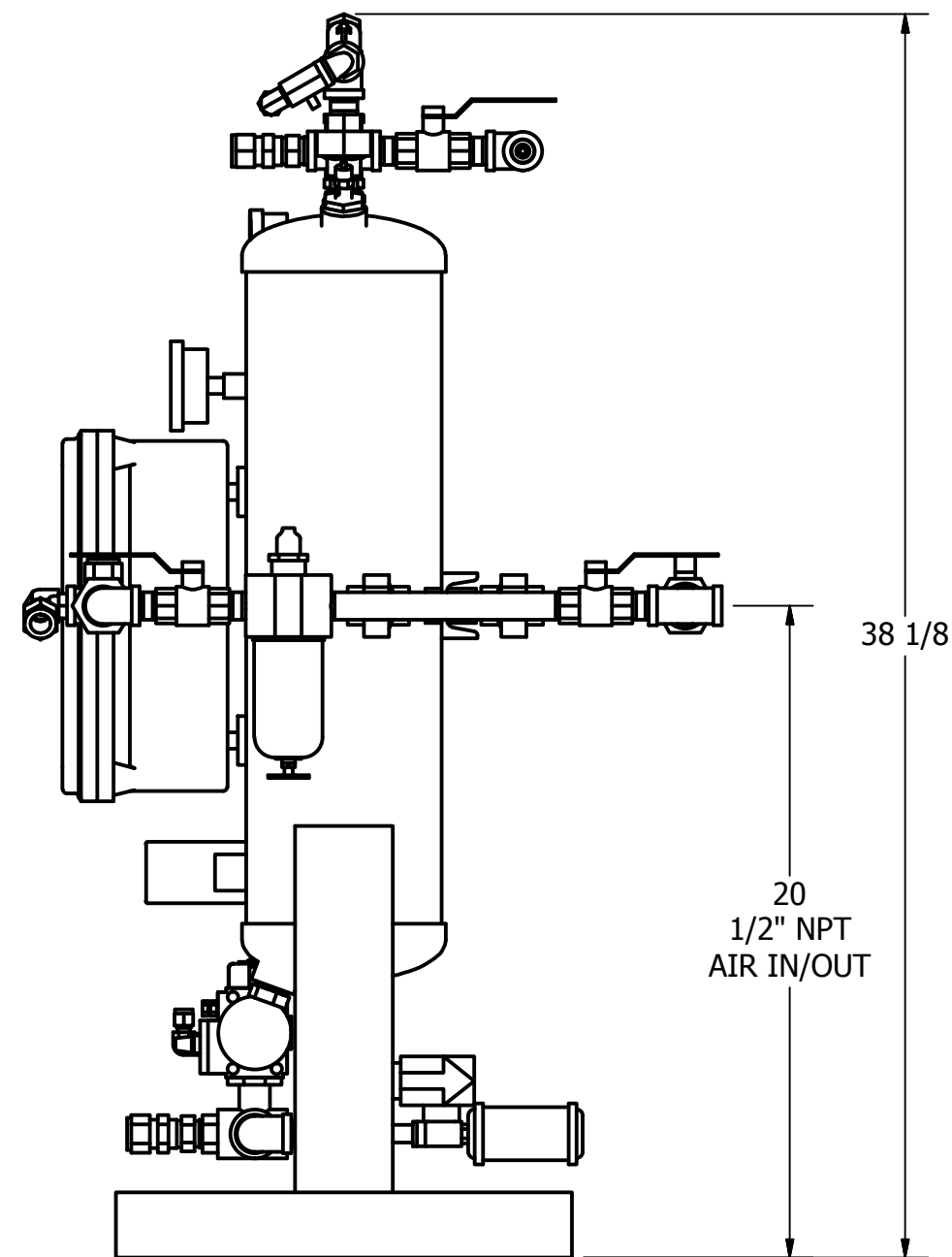
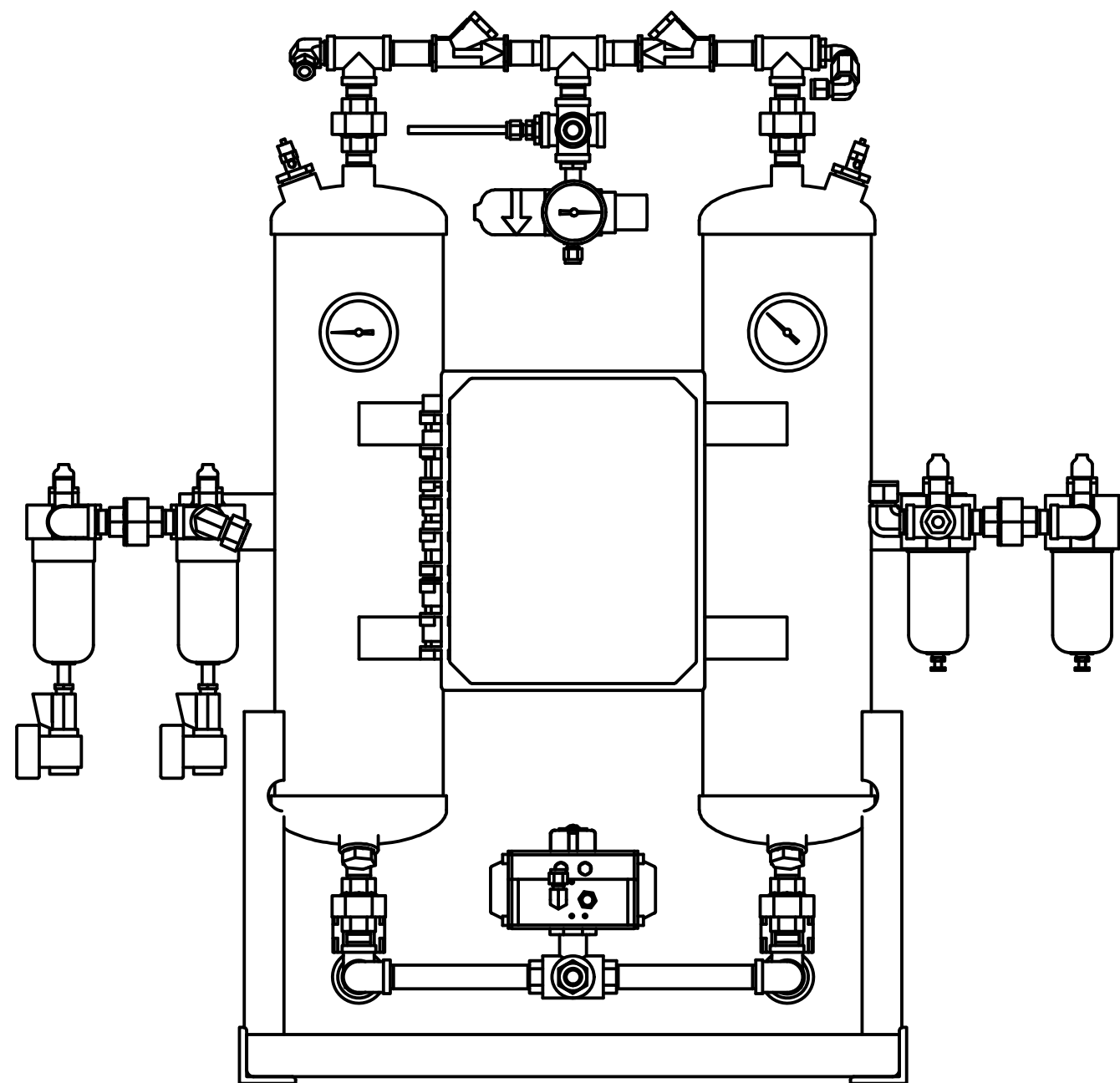
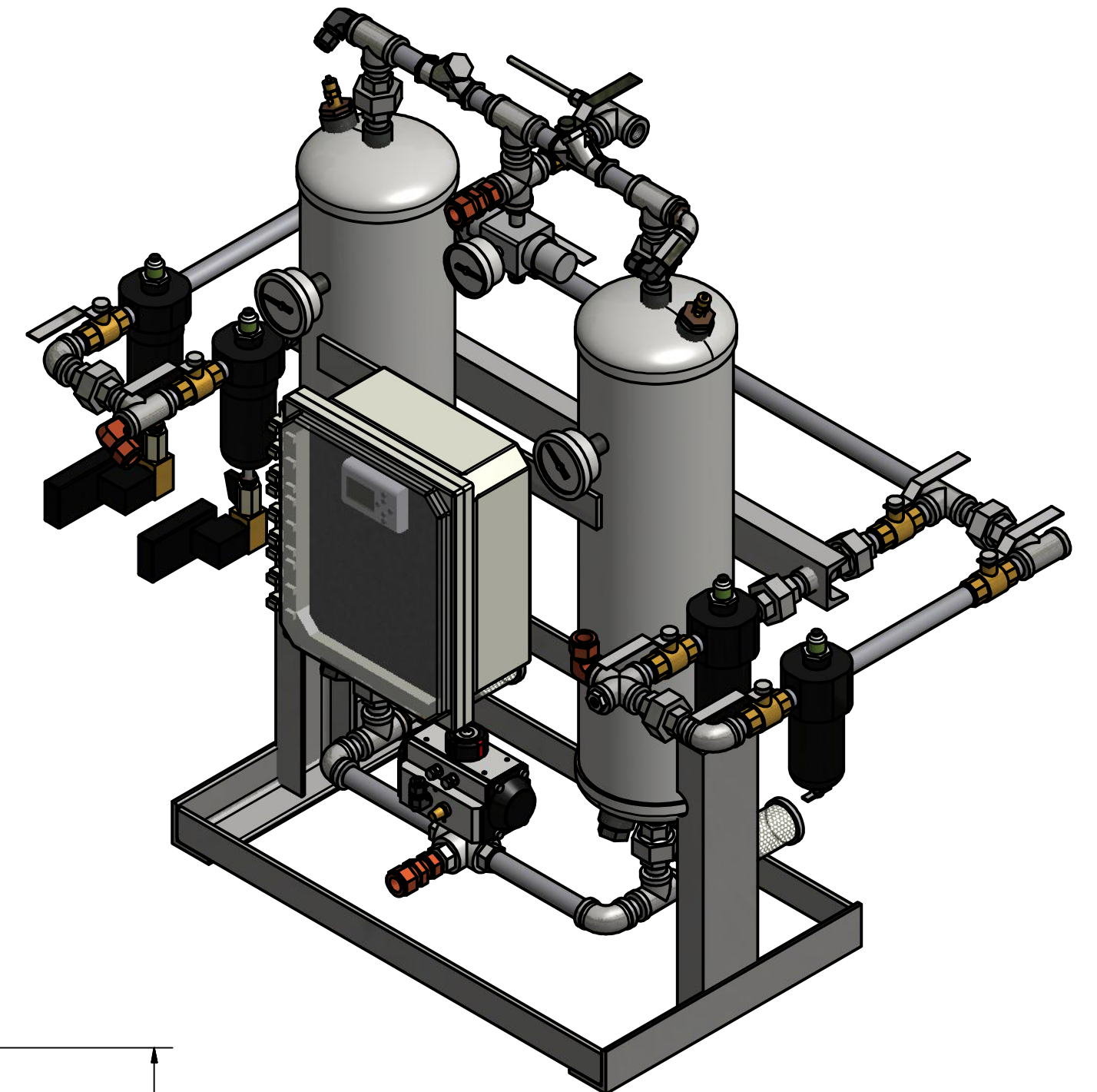
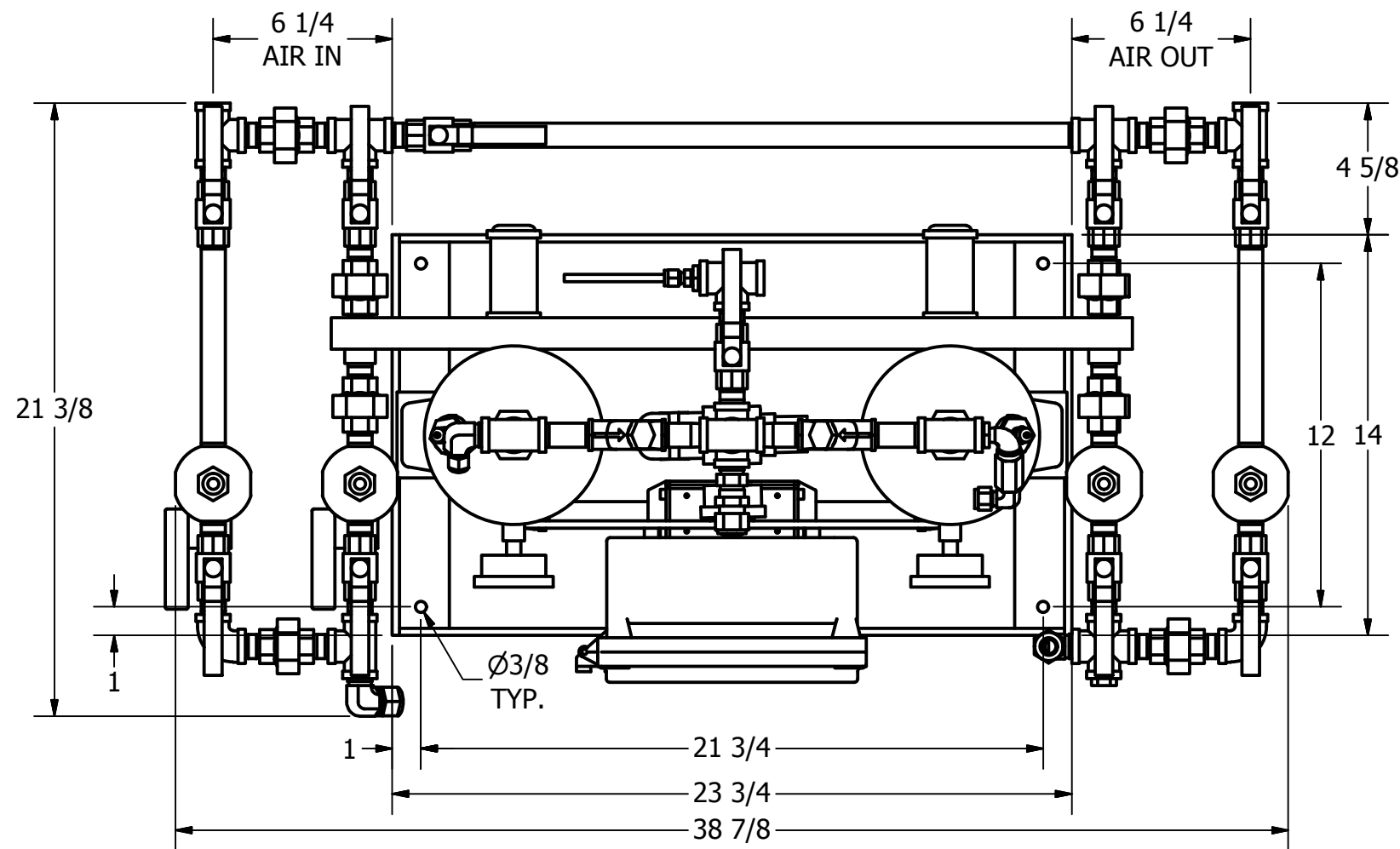

**PRELIMINARY**



# HRL-0025-1-9 HEATLESS DESICCANT AIR DRYER GENERAL ARRANGEMENT

TOLERANCES UNLESS  
OTHERWISE SPECIFIED:

- FRACTIONS = ± 1/4 "
- ANGLES = ± 3°
- INCHES = ± 1/2 "
- FINISH = 250

THE SPECIFICATIONS AND DRAWINGS DISCLOSED HEREIN ARE THE SOLE PROPERTY OF ALTEC AIR, AND SHALL NOT BE COPIED OR USED AS THE BASIS FOR SALE OR MANUFACTURE WITHOUT EXPRESS WRITTEN PERMISSION.

### REVISION LOG

REV.	ECO.	DESCRIPTION	DATE	APPROVED
A				

DRAWING NO.

AT20-1426

REV.

A

DRAWN: WS      DATE: 9/20/2021  
CHECKED:      DATE:

SCALE: N/A      SHEET: 2 OF 2

### PARTS LIST

ITEM	QTY	DESCRIPTION
1	2	CHECK VALVE, OUTLET
2	1	DEW POINT MONITOR (OPTIONAL)
3	2	PARTICULATE AFTER-FILTER
4	1	MOISTURE INDICATOR
5	1	PRESSURE REGULATOR, CONTROL
6	1	PRESSURE GAUGE, CONTROL
7	1	BALL VALVE, PURGE
8	2	PRESSURE GAUGE, TANK
9	1	3-WAY BALL VALVE, INLET
10	2	COALESCER PRE-FILTER
11	2	TIMER DRAIN
12	2	SOLENOID VALVE, EXHAUST
13	2	MUFFLER, EXHAUST
14	2	RELIEF VALVE, TANK
15	9	MANUAL BALL VALVE, BYPASS
16	30 LBS	DESICCANT

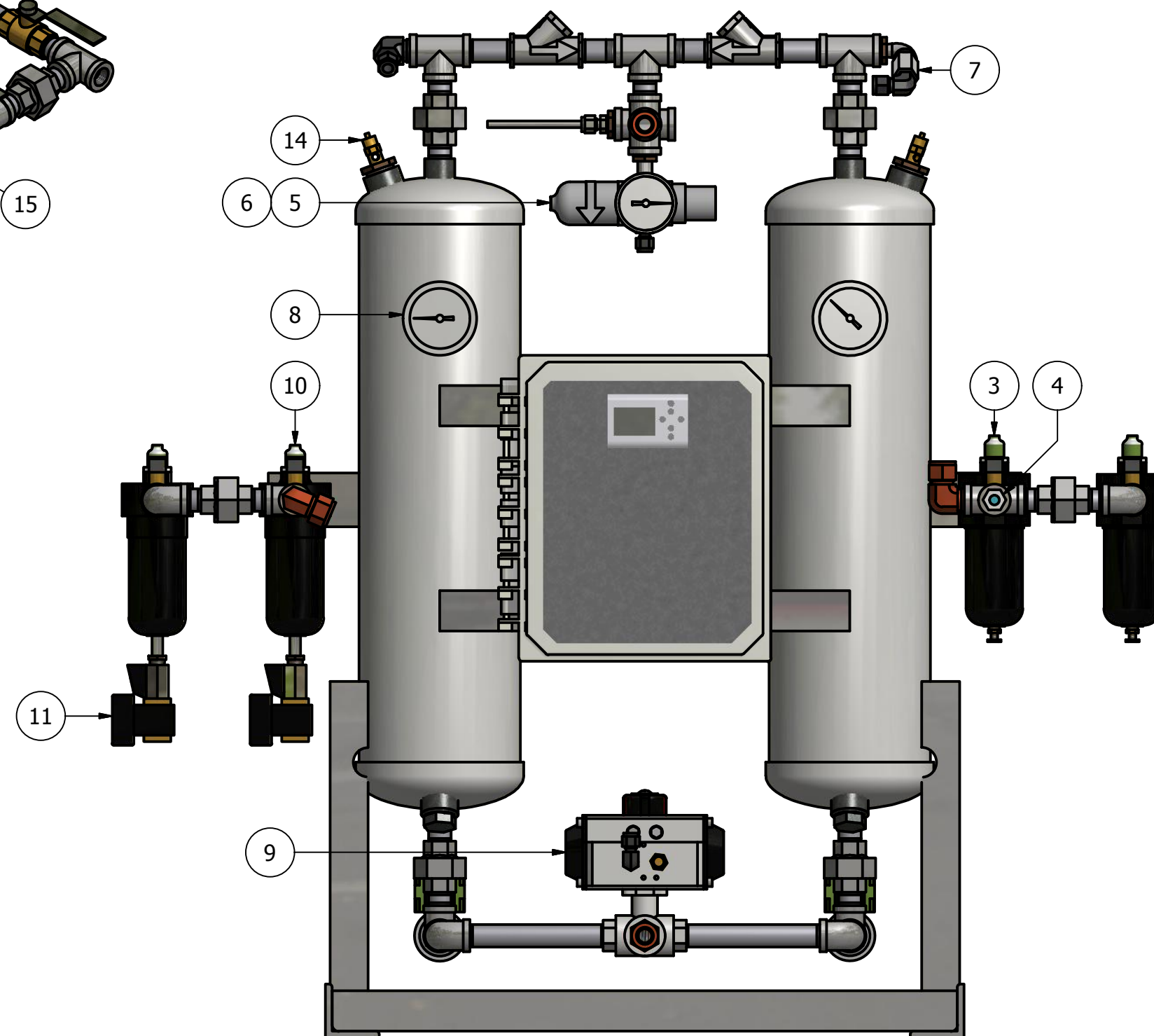
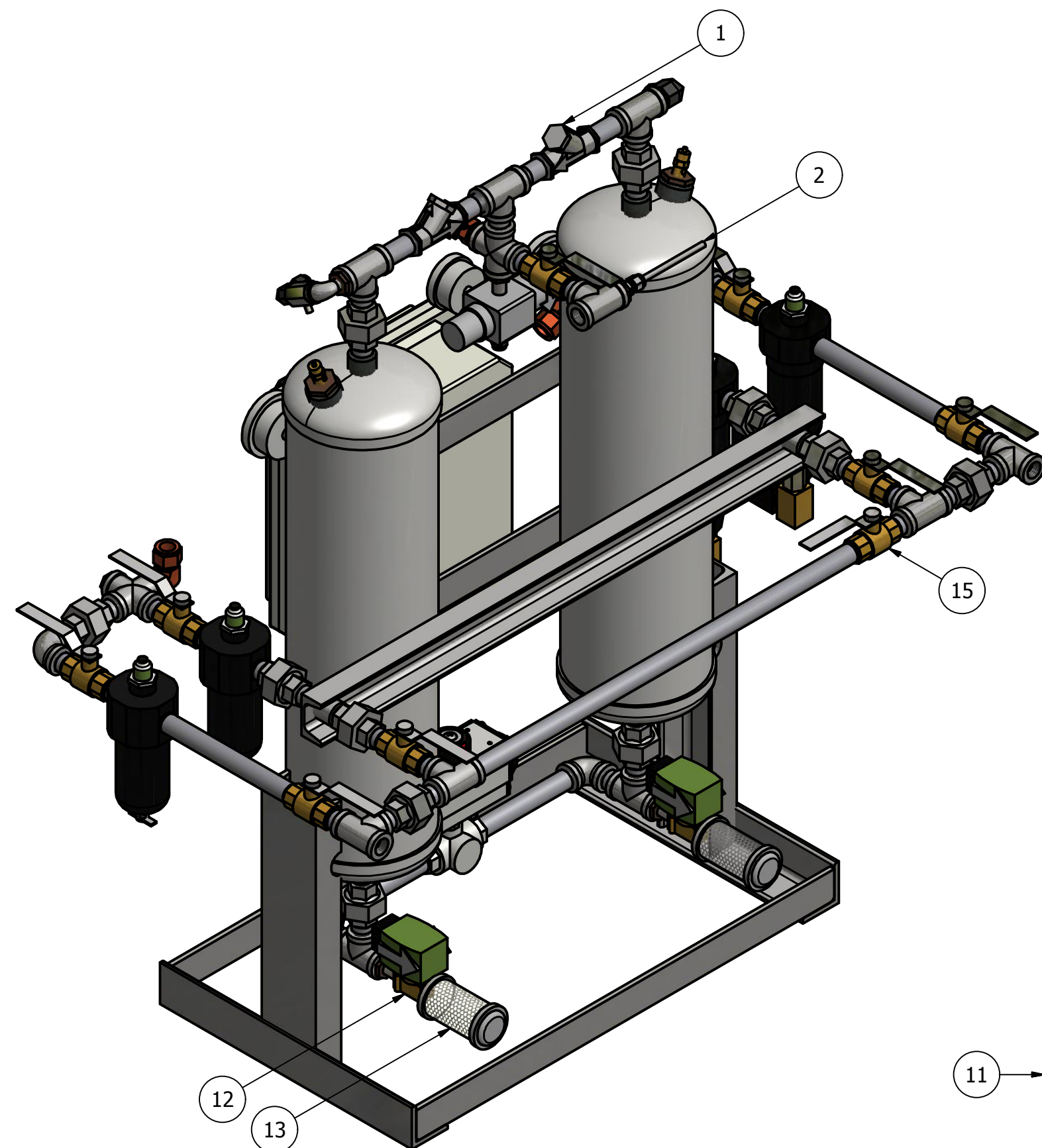

**PRELIMINARY**